

Radiation	Type	Electrodes
Infrared	AlGaAs	N (cathode) up

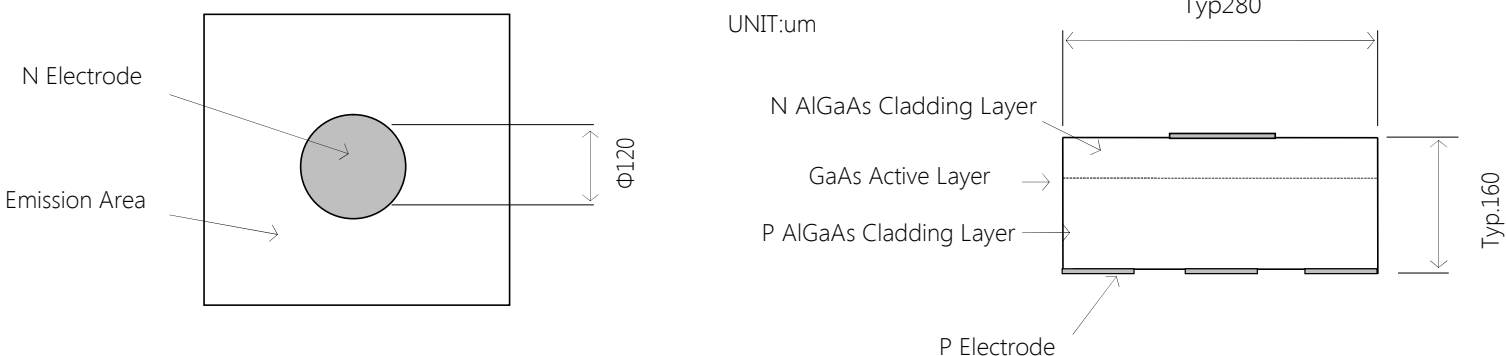

Physical Characteristics & Structure

Material: AlGaAs	Bond Pad Size: 120um diameter
Junction Size: 280um x 280um	Anode Metalization: Gold Alloy
Thickness: 160um	Cathode Metalization: Gold Alloy

Electrical & Optical Characteristics (Ta = 25°C)

ITEMS	SYMBOL	CONDITIONS	MIN	TYP	MAX	UNIT
Forward Voltage	Vf	If=20mA	--	--	1.6	V
Reverse Voltage	Vr	Ir=10uA	5	--	--	V
Radiant Power*	Φe	If=20mA	4.0	--	--	mW
Peak Wavelength	λp	If=20mA	875	885	895	nm
Spectral Bandwidth at 50%	Δλ0.5	If=20mA	--	55	--	nm
Rise Time	Tr	Ifp=100mA Tw=125ns, Duty=25%	--	20	--	ns
Fall Time	Tf	Ifp=100mA Tw=125ns, Duty=25%	--	20	--	ns
Peak Forward Voltage	Vfm	Ifp=200mA Tw=10us, Duty=10%	--	2.0	--	V

* LED chip is mounted on TO-18 gold header without resin coated.

Absolute Maximum Ratings (Ta = 25°C)

Continuous Maximum Forward Current: 100mA (DC)
 Reverse Voltage: 5V (IR=10uA)
 Storage Temperature
 while on mylar membrane: 0 to 40 °C
 after removal from mylar membrane: -30 to 100 °C



We reserve the right to make changes to improve technical design and may do so without further notice. Parameters can vary in different applications. All operating parameters must be validated for each customer application by the customer.